

FSI ELECTRONIC IGNITION CONVERSION KIT 6-VOLT, POSITIVE GROUND

INSTALLATION INSTRUCTIONS

**PLEASE READ INSTRUCTIONS CAREFULLY BEFORE INSTALLING YOUR KIT.
PLEASE FOLLOW WIRING DIAGRAM INCLUDED IN THESE INSTRUCTIONS.**

- ✓ This FSI Conversion Kit is designed for **6-volt positive ground only**.
- ✓ Please do not leave ignition switch on more than **30 seconds** without engine running. As with points & condenser, this may cause coil and module to overheat, possibly resulting in damage to one or both.
- ✓ This ignitor system requires an on-off switch (will not work with pop-out ignition switch). An after-market single-pole locking ignition switch is available from FS Ignitions and most auto part stores.

NO ORIGINAL WIRING IS USED ON THIS SYSTEM.

DO NOT CONNECT ORIGINAL RED OR BLACK WIRES FROM FIREWALL TERMINAL BOX TO COIL.

PRE-INSTALLATION CHECK

1. Check for loose or poor connections in ignition circuit.
2. Check battery terminals for corrosion and loose connections.
3. Replace any components that show deterioration.
4. Battery must be fully charged. Confirm voltage of 6 to 6.5 at battery with ignition off.

COIL INFORMATION

This 6-volt positive ground ignitor system will work with any coil (OEM or after-market high performance) that was designed for use with "points", regardless of voltage output. Minimum primary resistance of the coil must be 1.3 to 1.5 OHM. A lower primary resistance will provide too much current to the ignitor, causing it to burn out and VOID THE WARRANTY. To check the primary resistance of a coil, connect one lead of the OHM meter to the positive (+) post of the coil and one lead to the negative (-) post of the coil. For optimal results, check primary resistance when ambient temperature is 70°F.

INSTALLATION

1. **Use DiElectric gel on all connections.**
2. **For assistance at any time, contact FSI! (580-762-8322)**
3. **Disconnect the battery or fuse to ensure there is no voltage to the coil.**
4. **Disconnect all existing primary wiring from ignition system.**
5. Rotate engine to #1 cylinder TDC (top dead center), using pin in front timing cover. Make sure your distributor rotor points to #1 spark plug terminal in distributor cap. **Firing Order: 1,2,4,3 (counter-clockwise rotation)**. You may remove distributor from engine but it is not absolutely necessary.



OVER →

6. Remove rotor, cam, upper breaker plate with arm, and lower plate from your distributor housing (**your upper breaker plate with arm and lower plate from your distributor are not used with this system**).
7. Replace spring and install your new FSI upper breaker plate with ignitor attached. Leave enough wire inside the distributor so it will not rub against any moving parts.
8. Install cam then place magnet sleeve (white side up) onto the point cam from the top and push the sleeve down firmly. Air gap between magnet sleeve and ignitor is not critical. It must not rub and can be up to .060" clearance. Place your rotor onto point cam (above magnet sleeve).
9. Distributor can now be installed in engine.
10. Install new coil (included with distributor).
11. The **Black w/White Tracer Ignitor Wire** must connect to the negative (-) post of the coil (sometimes marked DIST).
12. The **Solid Black Ignitor Wire** (longer) must connect directly to the ignition switch
13. **IF IGNITOR WIRES ARE REVERSED, THE UNIT MAY BE DESTROYED!**
14. Ground the **Short Red Wire** from the positive (+) post of the coil to the lower right wiring terminal box mounting screw **inside** firewall (same screw as yellow wire in next step).
15. The **Yellow Ground Wire from Distributor** should go to the **inside** of the firewall and be grounded to the lower right wiring terminal box mounting screw. Remove small amount of paint for good metal to metal contact. Any good ground to the firewall will work, this is a convenient spot.
16. All three wires (black, black w/white tracer, and yellow) should be run in wound-spring conduit, provided.
17. Connect the **Dedicated Ignition Wire w/Inline (20amp) Fuse (included)** from the **5/16 bolt on the negative battery cable clamp to the ignition switch battery terminal**. This ensures full voltage and allows the battery to act as a buffer against voltage spikes. (The generator/alternator and starter circuits seem to have a tendency to produce unwanted spikes that are hard on sub-miniature electronic devices.) All of this can be done through the battery inspection plate. The floorboards do not need to be removed to do this work.
18. **This system DOES NOT utilize a condenser or external ballast resistor. (condenser can be left in distributor housing for appearance only but MUST NOT be electrically connected).**

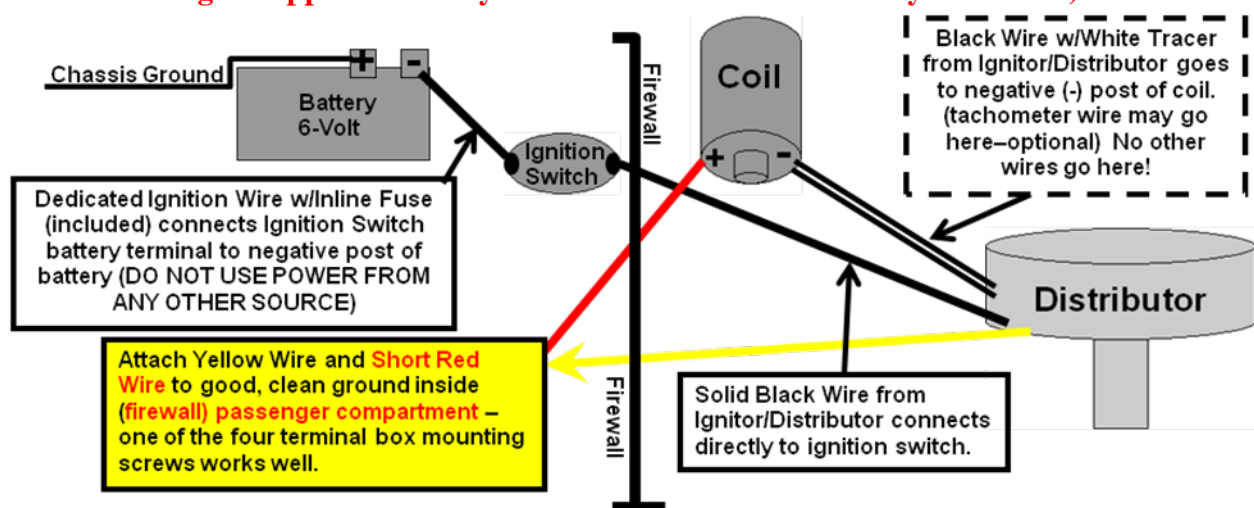

19. Connect coil wire and spark plug connectors. **Firing Order: 1,2,4,3 (counter-clockwise rotation)**. Re-connect battery cable.
20. After wiring is complete and the spark handle is in the retard position, align rotor with #1 terminal of distributor cap as shown, and tighten screw.
21. The engine may now be started. Set timing (see Trouble-Shooting Guide, included).

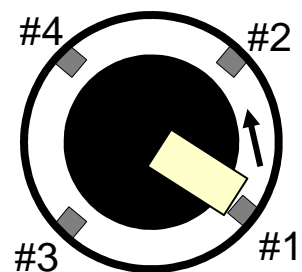

Never hesitate to contact us if you have questions (580-762-8322).

Enjoy!

J. D. Hanks and Mel Mallory, FSI Partners

Revised 8/2/2011