

FSI ELECTRONIC IGNITION CENTRIFUGAL ADVANCE DISTRIBUTOR 6-VOLT, POSITIVE GROUND

INSTALLATION INSTRUCTIONS

**PLEASE READ INSTRUCTIONS CAREFULLY BEFORE INSTALLING YOUR DISTRIBUTOR
PLEASE FOLLOW WIRING DIAGRAM INCLUDED IN THESE INSTRUCTIONS.**

- ✓ This FSI Distributor is designed for **6-volt, positive ground only**.
- ✓ Please do not leave ignition switch on more than **30 seconds** without engine running. As with points & condenser, this may cause coil and module to overheat, possibly resulting in damage to one or both.
- ✓ This Ignitor system requires an on-off switch (will not work with a pop-out ignition switch), available from FS Ignitions and most auto part stores.
- ✓ If the distributor you are removing has a long shaft, the new distributor will require an intermediate shaft to be the proper length (stainless steel intermediate shaft available from FS Ignitions).
- ✓ This FSI distributor uses modern spark plug wires (radio suppression spark plug wires available from FS Ignitions)
- ✓

NO ORIGINAL IGNITION WIRING IS USED ON THIS SYSTEM.

DO NOT CONNECT ORIGINAL RED OR BLACK WIRES FROM FIREWALL TERMINAL BOX TO COIL.

PRE-INSTALLATION CHECK

1. Check for loose or poor connections in ignition circuit.
2. Check battery terminals for corrosion and loose connections.
3. Replace any components that show deterioration.
4. Battery must be fully charged. Confirm voltage of 6 to 6.5 at battery with ignition off.

COIL INFORMATION

This 6-Volt positive ground Ignitor system will work with any coil (OEM or after-market high performance) that was designed for use with "points", regardless of voltage output. Minimum primary resistance of the coil must be 1.3 to 1.7 OHM. A lower primary resistance will provide too much current to the Ignitor, causing it to burn out and VOID THE WARRANTY. To check the primary resistance of a coil, connect one lead of the OHM meter to the positive (+) post of the coil and one lead to the negative (-) post of the coil. For optimal results, check primary resistance when ambient temperature is 70°F.



- 1) **Use DiElectric gel on all ignition connections.**
- 2) **For assistance any time, contact FSI! (580-762-8322)**
- 3) **Disconnect the battery or fuse to ensure there is no voltage to the coil.**
- 4) **Disconnect all existing primary wiring from ignition system.**
- 5) Rotate engine to #1 cylinder TDC (top dead center), using pin in front timing cover. Remove your distributor.
- 6) Recommendation: Apply light grease or Anti-Seize compound into hole in head.
- 7) Install the FSI Distributor into the head and ensure that it has dropped into the distributor drive slot. **OVER**→

8) Turn the distributor housing to line the rotor with the spark plug tower you plan on using for #1 spark plug. (If you are concerned with the position of the distributor, you can remove the valve cover and rotate the distributor drive gear for proper alignment).

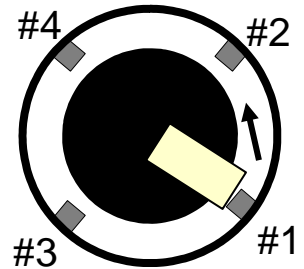

Firing Order: 1,2,4,3 (counter-clockwise rotation).

9) Snug the distributor locking screw & nut into the head to hold the distributor in place – DO NOT OVER-TIGHTEN (over-tightening can warp the shaft housing).

10) Install new coil (included with distributor).

11) The **Black w/White Tracer Ignitor Wire** must connect to the negative (-) post of the coil (sometimes marked DIST).

12) The **Solid Black Ignitor Wire** (longer) must connect directly to the ignition switch

13) **IF IGNITOR WIRES ARE REVERSED, THE UNIT MAY BE DESTROYED!**

14) Ground the **Short Red Wire** from the positive (+) post of the coil to the lower right wiring terminal box mounting screw **inside** firewall (same screw as yellow wire in next step).

15) The **Yellow Ground Wire from Distributor** should go to the **inside** of the firewall and be grounded to the lower right wiring terminal box mounting screw. Remove small amount of paint for good metal to metal contact. Any good ground to the firewall will work, this is a convenient spot.

16) All three wires (black, black w/white tracer, and yellow) should be run in cloth conduit, provided.

17) Connect the **Dedicated Ignition Wire w/Inline (20amp) Fuse (included)** from the **5/16 bolt on the negative battery cable clamp to the ignition switch battery terminal**. This ensures full voltage and allows the battery to act as a buffer against voltage spikes. (The generator/alternator and starter circuits seem to have a tendency to produce unwanted spikes that are hard on sub-miniature electronic devices.) All of this can be done through the battery inspection plate. The floorboards do not need to be removed to do this work.

18) **This system DOES NOT utilize a condenser or external ballast resistor.**

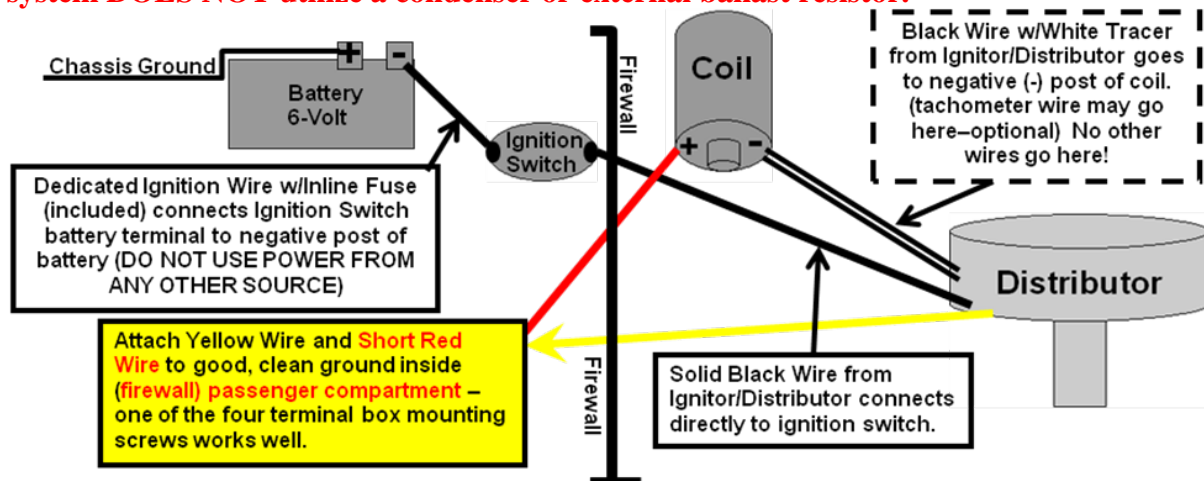

19) Connect coil wire and spark plug wires. **Firing Order: 1,2,4,3 (counter-clockwise rotation).** Re-connect battery cable.

20) The engine may now be started.

Timing:

Set timing (see Trouble-Shooting Guide included). The FSI Electronic Ignition Centrifugal Advance Distributor has 28° to 29° of centrifugal advance @ 1750-2250 RPM - this seems to work well on the “stock” engine. The springs are light enough (.020) that the advance occurs quickly. Engine timing is a little different for each car and driver. It may require experimentation to determine what works for you and your “A”. Listen for “ping” or “spark-knock” while driving the vehicle under heavy load. If this occurs, retard the timing 2° - 4° until knock goes away.

Never hesitate to contact us if you have questions (580-762-8322). Enjoy!

J. D. Hanks and Mel Mallory, FSI Partners

Revised 8/8/13