

FSI ZIPPER ELECTRONIC IGNITION CENTRIFUGAL ADVANCE DISTRIBUTOR 12-VOLT, NEGATIVE GROUND

INSTALLATION INSTRUCTIONS

**PLEASE READ INSTRUCTIONS CAREFULLY BEFORE INSTALLING YOUR DISTRIBUTOR
PLEASE FOLLOW WIRING DIAGRAM INCLUDED IN THESE INSTRUCTIONS.**

- ✓ This FSI ZIPPER Distributor is designed for **12-volt, negative ground only**.
- ✓ Please do not leave ignition switch on more than 30 seconds without engine running. As with points & condenser, this may cause coil and module to overheat, possibly resulting in damage to one or both.
- ✓ This ignitor system requires an on-off switch (will not work with a pop-out ignitions switch), available from FS Ignitions and most auto part stores.
- ✓ If the distributor you are removing has a long shaft, the new distributor will require an intermediate shaft to be the proper length (stainless steel intermediate shaft available from FS Ignitions).
- ✓ Oiler and Condenser are non-functional. The bushings self-lube.
- ✓ Model "B" copper spark plug connectors are slightly longer and work best with the *Zipper*, included.

**EXCEPT FOR ONE WIRE FROM POSITIVE POST OF COIL TO IGNITION SWITCH,
NO ORIGINAL WIRING IS USED ON THIS SYSTEM.**

DO NOT CONNECT ORIGINAL RED OR BLACK WIRES FROM FIREWALL TERMINAL BOX TO COIL.

PRE-INSTALLATION CHECK

1. Check for loose or poor connections in ignition circuit.
2. Check battery terminals for corrosion and loose connections.
3. Replace any components that show deterioration.
4. Battery must be fully charged. Confirm voltage of 12 to 13 at battery with ignition off.



COIL INFORMATION

This 12-Volt negative ground Ignitor system will work with any coil (OEM or after-market high performance) that was designed for use with "points", regardless of voltage output. Minimum primary resistance of the coil must be 3.0 – 3.5 OHM. A lower primary resistance will provide too much current to the Ignitor, causing it to burn out and VOID THE WARRANTY. To check the primary resistance of a coil, connect one lead of the OHM meter to the positive (+) and one lead to the negative (-) terminal of the coil. For optimal results, check primary resistance when ambient temperature is 70°F.

- 1) **Use DiElectric gel on all ignition connections.**
- 2) **For assistance any time, contact FSI! (580-762-8322)**
- 3) **Disconnect the battery or fuse to ensure there is no voltage to the coil.**
- 4) **Disconnect all existing primary wiring from ignition system.**
- 5) Rotate engine to #1 cylinder TDC (top dead center), using pin in front timing cover. Make sure your distributor rotor points to #1 spark plug terminal in distributor cap. Remove your distributor.
- 6) Recommendation: Apply light grease or Anti-Seize compound into hole in head.
- 7) Install your FSI *Zipper* Distributor into the head and ensure that it has dropped into the distributor drive slot.
- 8) Align the distributor cap parallel to the head.
- 9) Snug your distributor locking screw & nut into the head to hold the distributor in place.

OVER →

10) Remove the rotor from your FSI *Zipper* distributor and loosen the screw (positioned just beneath the rotor). Put the rotor back in place, setting it to the same position as your old distributor rotor was pointing. Making sure that the cam does not move from that position, remove the rotor again, retighten the screw, and put the rotor back into place. Place Zipper distributor cap onto distributor, confirming that the rotor is aligned with #1 spark plug terminal of distributor cap, as shown. **Firing Order: 1,2,4,3 (counter-clockwise rotation).**

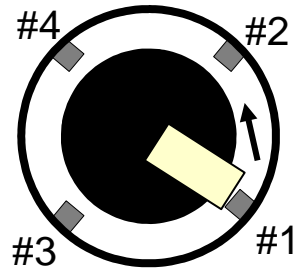

11) Install new coil (included with distributor).

12) The **Black Ignitor/Distributor Wire** must connect to the negative (-) post of the coil (sometimes marked DIST).

13) The **Red Ignitor/Distributor Wire** must connect to the positive (+) post of the coil (sometimes marked BAT). (The positive (+) coil side is also the side that is fed by the ignition switch.)

14) **IF IGNITOR WIRES ARE REVERSED, THE UNIT MAY BE DESTROYED!**

15) The **Yellow Ground Wire from Distributor** should go to the inside of the firewall and be grounded to the lower right wiring terminal box mounting screw. Remove small amount of paint for good metal to metal contact. Any good ground to the firewall will work, this is a convenient spot.

16) All three wires (black, red, and yellow) should be run in wound-spring conduit, provided.

17) Connect the **Dedicated Ignition Wire w/Inline (20amp) Fuse (included)** from the **5/16 bolt on the positive battery cable clamp to the ignition switch battery terminal**. This ensures full voltage and allows the battery to act as a buffer against voltage spikes. (The generator/alternator and starter circuits seem to have a tendency to produce unwanted spikes that are hard on sub-miniature electronic devices.) All of this can be done through the battery inspection plate. The floorboards do not need to be removed to do this work.

18) **This system DOES NOT utilize a condenser or external ballast resistor.**

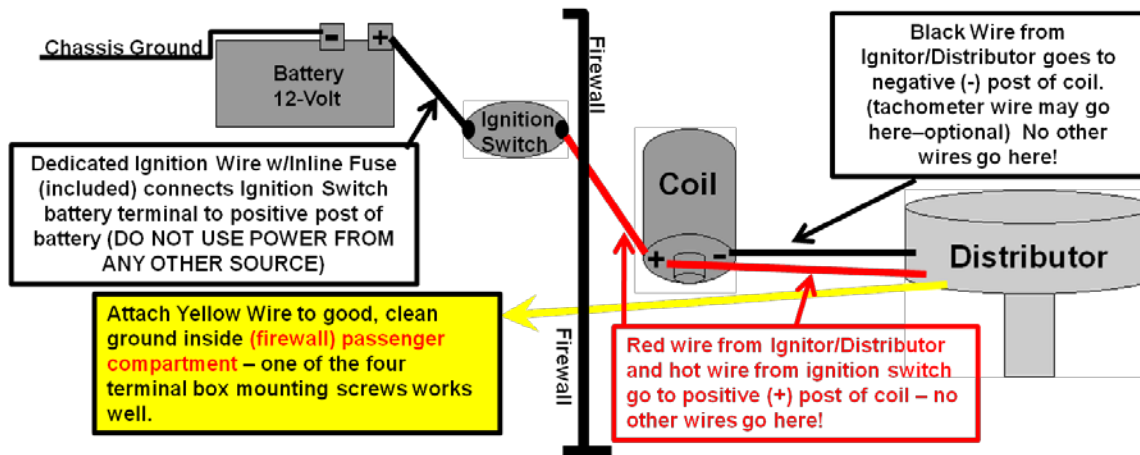

19) Connect coil wire and spark plug connectors. **Firing Order: 1,2,4,3 (counter-clockwise rotation).** Re-connect battery cable.

20) The engine may now be started.

Timing:

Set timing (see Trouble-Shooting Guide included). Start timing at TDC at idle. The FSI *Zipper* Electronic Ignition Centrifugal Advance Distributor has 26° to 28° of centrifugal advance – this seems to work well on the “stock” engine. The springs are light enough (.020) that the advance occurs quickly.

Never hesitate to contact us if you have questions (580-762-8322). Enjoy!

J. D. Hanks and Mel Mallory, FSI Partners

(Revised 8/2/11)